

BRISTAN

**Design Utility Kitchen Ranges
(Club, Crosshead and Lever)**

Fitting Instructions & Contents List



Please keep these instructions for future reference and request of replacement parts

Introduction

Thank you for choosing Bristan, the UK's leading taps and showers expert. We have designed this product with your enjoyment in mind. To ensure that it works to its full potential, it needs to be fitted correctly. These fitting instructions have been created to give you all of the information you need and, if you need any further help, please do not hesitate to give us a call on 0844 701 6273.

Safety Note

Please read these instruction thoroughly and retain for future use.

All product manufactured and supplied by Bristan are safe provided they are installed correctly, used correctly and receive regular maintenance in accordance with these instructions.

These fittings need to be installed in accordance with and meet the requirements of the Water Supply (Water Fittings) Regulations 1999 and Scottish Byelaws 2004.

Water Pressure

These products are suitable for use at all supply pressures. If installed at low pressure (tank fed), then the minimum distance from the outlet of the nozzle to the underside of the cold tank should be approximately 2 metres to ensure adequate performance. The taps should be installed in compliance with Water Regulations. For further details contact your Local Water Authority.

Installation – High Neck Taps

1. Identify all components and check for completeness, particularly before arranging fitting.
2. Install the taps (3) to the basin/sink. The backnut (1) and backnut washer (2) are used under the basin/sink to secure the tap to the surface of basin/sink.
3. Connect the hot and cold water supplies to the taps.
4. Turn on the water supplies. Open both taps letting the water flow for a few minutes to check all joints and connections for leaks.

Contents

1. Backnut	x2
2. Backnut Washer	x2
3. Body	x2
4. Valve	x2
5. Handle	x2
6. Handle Screw	x2
7. Indices	x2

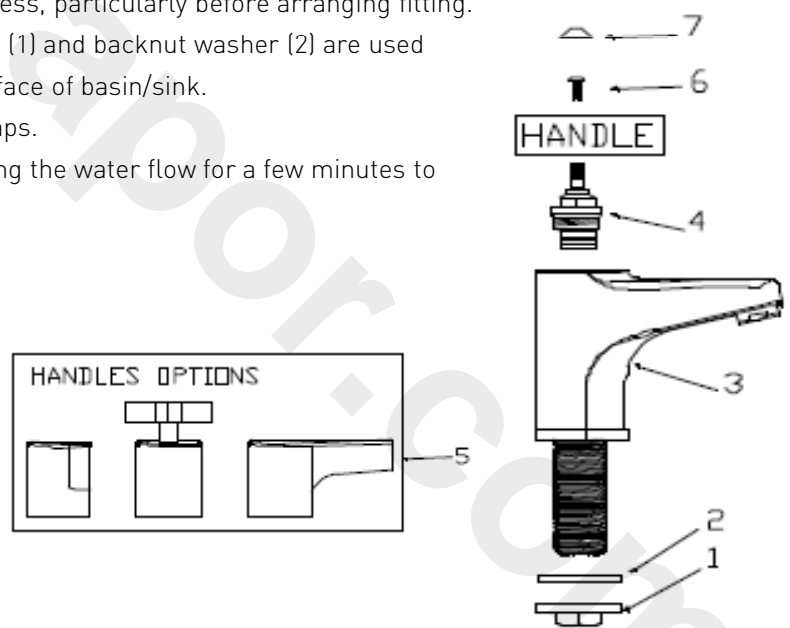

Deck Sink Mixer

1. Identify all components and check for completeness, particularly before arranging fitting.
2. Attach the spout into the body (3), secure in place with the grub screw ensuring the spout is able to rotate freely.
3. Fit the mixer to the sink using the backnut washers (2) and backnuts (1) below the surface. Then connect the hot and cold water supplies to the mixer.
4. Fully open both valves, letting the water run for a few minutes to check all connections for leaks.

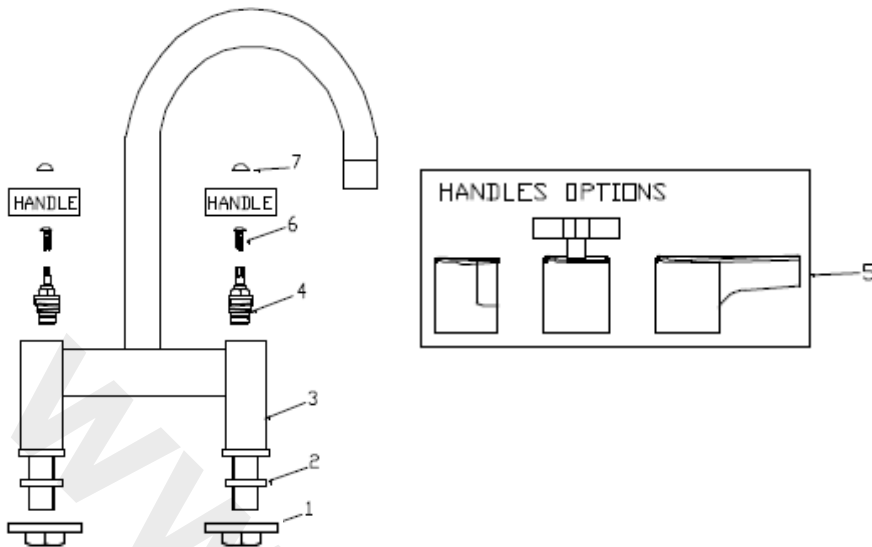

Contents

1.	Backnut	x2
2.	Backnut Washer	x2
3.	Body	x1
4.	Valve	x2
5.	Handle	x2
6.	Handle Screw	x2
7.	Indices	x2

Sink Mixer

1. Identify all components and check for completeness, particularly before arranging fitting.
2. Fit the mixer (3) to the sink using the fixing kit (10).
3. Screw in connecting copper tail pipes (11) by hand into base of the mixer and then connect to the hot and cold supplies.
4. Fully open both valves, letting it run for a few minutes to check all connections

for leaks.

Contents

3.	Body	x1	10.	Fixing kit	x1
4.	Valve	x2	11.	Tail pipes	x2
5.	Handle	x2	12.	Shrouds	x2
6.	Handle Screw	x2	16.	Grub screw	x1
7.	Indices	x2			

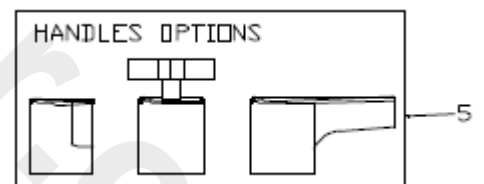
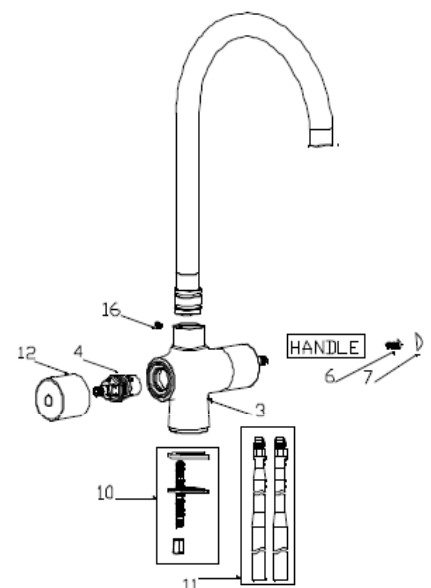

IMPORTANT - PLEASE READ

These fittings need to be installed in accordance with the following Installation Requirements and Notes (IRN) to ensure they meet the requirements of the Water Supply (Water Fittings) Regulations 1999 and the Scottish Byelaws 2004.

IRN R001 (DUL / DUC / DUX HNK / SNK DSM C)

See text of entry for Installation Requirements or Notes.

IRN R006 (DUL / DUC / DUX HNK / SNK / DSM C)

This tap or combination tap assembly has a Type AUK3 air gap and is therefore for installation in any premises to protect against a backflow risk up to a Fluid Category 5.

IRN R010 (DUL / DUC / DUX SNK / DSM C)

Schedule 2-15 (1)

Water supplies shall be a reasonably balanced pressures from a common source (e.g. hot and cold supplies both from the same storage or both from a supply pipe). Where the fitting is supplied from unbalanced supplies (e.g. hot and cold supplies from separate sources) a Listed' single check valve or some other no less effective backflow prevention device shall be fitted immediately upstream of both hot and cold water inlets.



Guarantee

Maintenance

If any of the fittings begin to drip:

1. Turn off the water supply.
2. Remove the indices cap (7) and screw (6), and then remove the handle (5) by pulling from valve (4). The remove valve (4).
3. Once removed, carefully clean seating, rubber washer and ceramic disc.
4. Replace all of the above then turn on the water supply.
5. If the problem persists contact our customer services helpline.

Bristan Guarantee

Bristan offers solid guarantees to provide you with complete peace of mind.

Taps and Mixers

5 year parts and 1 year labour*. Gold painted and special finishes 3 years parts only.

All subject to proof of purchase.

*Labour provided by an approved Bristan engineer. Guarantee only applies to products with a manufacturing fault. A deferred payment will be necessary in order to secure any visits by our engineers which will be charged if the problem is found **not** to be a manufacturing fault. If the fault is found to be down to a manufacturing error, the payment will be released and not charged.

This guarantee applies to products purchased within the United Kingdom or Republic of Ireland, but does not apply to products used commercially.

The guarantee is only available to original purchasers who have proof of purchase.

The installation must allow ready access to all products for the purpose of inspection, maintenance or replacement.

Any part found to be defective during the above guarantee period will be replaced without charge, providing that the product has been installed in accordance with the instructions, used as intended, and regularly serviced.

Servicing should be carried out at regular intervals of no more than 12 months and more frequently in hard water areas (heavy lime scale) areas.

In the unlikely event that any problems are encountered with the product's performance on installation, you must obtain guidance/authorisation from our Customer Service Department, and be able to supply proof and date of purchase, before any remedial action is taken.

The guarantee excludes general wear and tear and damage caused by accident, misuse or neglect, and does not cover the following:

- Components that are subject to general wear and tear such as filters, seals, 'O' rings and washers etc.
- Damage caused by faulty installation
- Damage caused by lime scale or any waterborne debris
- Damage caused by inappropriate cleaning products (see user instructions)
- Damage caused by the use of non-Bristan parts
- The product being used for a purpose other than intended by the manufacturer.

In the interests of continuous product improvement Bristan reserves the right to alter specification as necessary.

If your product is out of its guarantee period, or you would like to extend the guarantee, then please see our [extended warranty offer](#).

This booklet covers all product codes

DUC HNK C / DUX HNK C / DUL HNK C / DUC DSM C / DUX DSM C / DUL DSM C /

DUC SNK C / DUX SNK C / DUL SNK C

Helpline

0844 701 6273

Bristan Group Limited

A Masco Company

Birch Coppice Business Park, Dordon, Tamworth, Staffordshire B78 1SG

Website: www.bristan.com

Telephone: 0844 7016 274

Facsimile: 0844 701 6275

Email: enquire@bristan.com